



TRUE MANUFACTURING CO., INC.
U.S.A. FOODSERVICE DIVISION

2001 East Terra Lane • O'Fallon, Missouri 63366-4434 • (636)240-2400
Fax (636)272-2408 • Toll Free (800)325-6152 • Intl Fax# (001)636-272-7546
Parts Dept. (800)424-TRUE • Parts Dept. Fax# (636)272-9471 • www.truemfg.com

Project Name: _____

Location: _____

Item #: _____ Qty: _____

Model #: _____

A/A #

SIS #

Model:
TUC-48F-D-4-HC

Undercounter:
Drawered Freezer with Hydrocarbon Refrigerant



TUC-48F-D-4-HC

- ▶ True's undercounter units are designed with enduring quality that protects your long term investment.
- ▶ Designed using the highest quality materials and components to provide the user with colder product temperatures, lower utility costs, exceptional food safety and the best value in today's food service marketplace.
- ▶ Factory engineered, self-contained, capillary tube system using environmentally friendly R290 hydrocarbon refrigerant that has zero (0) ozone depletion potential (ODP), & 0.02 global warming potential (GWP).
- ▶ Oversized, environmentally friendly forced-air refrigeration system holds -10°F (-23.3°C). Ideally suited for both frozen foods and ice cream.
- ▶ All stainless steel front, top and ends. Corrosion resistant GalFan coated steel back.
- ▶ Interior - attractive, clear coated aluminum liner with stainless steel floor.
- ▶ Each drawer accommodates one (1) full size 12"L x 18"W x 6"D (305 mm x 458 mm x 153 mm) food storage box (sold separately).
- ▶ Automatic defrost system time-initiated, time-terminated.
- ▶ Foamed-in-place using a high density, polyurethane insulation that has zero ozone depletion potential (ODP) and zero global warming potential (GWP).

Castor Options

**36"
Work Surface
Height**



Standard 5" Castors

**34"
Work Surface
Height**



ADA 3" Castors

**31-7/8"
Work Surface
Height**



Low Profile (LP) 1½" Castors
Upcharge applies for (LP) size castors

ROUGH-IN DATA

Specifications subject to change without notice.
Chart dimensions rounded up to the nearest 1/8" (millimeters rounded up to next whole number).

Model	Drawers	Cabinet Dimensions (inches) (mm)			HP	Voltage	Amps	NEMA Config.	Cord Length (total ft.) (total m)	Crated Weight (lbs.) (kg)
		W	D†	H*						
TUC-48F-D-4-HC	4	48¾ 1227	30¾ 764	29¾ 756	½ ½	115/60/1 220-240/50-60/1	4.6 2.0	5-15P	10 3.05	325 148

† Depth does not include 1" (26 mm) for rear bumpers.

* Height does not include 6¼" (159 mm) for castors or 6" (153 mm) for optional legs.



APPROVALS:

AVAILABLE AT:

4/26

Printed in U.S.A.

Model:
TUC-48F-D-4-HC

Undercounter:
Drawered Freezer with Hydrocarbon Refrigerant



STANDARD FEATURES

DESIGN

- True's commitment to using the highest quality materials and oversized refrigeration systems provides the user with colder product temperatures, lower utility costs, exceptional food safety and the best value in today's food service marketplace.

REFRIGERATION SYSTEM

- Factory engineered, self-contained, capillary tube system using environmentally friendly R290 hydrocarbon refrigerant that has zero (0) ozone depletion potential (ODP), & 0.02 global warming potential (GWP).
- Oversized, factory balanced refrigeration system with guided airflow to provide uniform product temperatures.
- High capacity, factory balanced refrigeration system that maintains -10°F (-23.3°C) temperatures. Ideal for both frozen foods and ice cream.
- State of the art, electronically commutated evaporator and condenser fan motors. ECM motors operate at higher peak efficiencies and move a more consistent volume of air which produces less heat, reduces energy consumption and provides greater motor reliability.
- Condensing unit access in back of cabinet, slides out for easy maintenance.
- Automatic defrost system time-initiated, time-terminated.

CABINET CONSTRUCTION

- Exterior - stainless steel front, top and ends. Corrosion resistant GalFan coated steel back.

- Interior - attractive, clear coated aluminum liner. Stainless steel floor with covered corners.
- Insulation - entire cabinet structure and drawer facings are foamed-in-place using a high density, polyurethane insulation that has zero ozone depletion potential (ODP) and zero global warming potential (GWP).
- 5" (127 mm) diameter stem castors - locks provided on front set. 36" (915 mm) work surface height.

DRAWERS

- Stainless steel exterior drawer facings and liners. Stainless steel drawer frames.
- Each drawer fitted with 12" (305 mm) long recessed handle that is foamed-in-place with a sheet metal interlock to ensure permanent attachment.
- Magnetic drawer gaskets of one piece construction, removable without tools for ease of cleaning.
- Heavy-duty stainless steel drawer slides and rollers. Removable without tools for easy cleaning.
- Each drawer accommodates one (1) full size 12"L x 18"W x 6"D (305 mm x 458 mm x 153 mm) food storage box or one ½ size and one ½ size pans (sold separately).

MODEL FEATURES

- Evaporator is epoxy coated to eliminate the potential of corrosion.
- NSF/ANSI Standard 7 compliant for open food product.

ELECTRICAL

- Unit completely pre-wired at factory and ready for final connection to a 115/60/1 phase, 15 amp dedicated outlet. Cord and plug set included.



115/60/1
NEMA-5-15R

OPTIONAL FEATURES/ACCESSORIES

Upcharge and lead times may apply.

- 230-240V / 50-60 Hz.
- 6" (153 mm) standard legs.
- 6" (153 mm) seismic/flanged legs.
- 2 ½" (64 mm) diameter castors.
- Single overshelf.
- Double overshelf.
- Stacking collar.
- 30" (762 mm) deep, ½" (13 mm) thick, white polyethylene cutting board. Requires "L" brackets.
- 30" (762 mm) deep, ½" (13 mm) thick, composite cutting board. Requires "L" brackets.
- Heavy duty 16 gauge tops.
- Exterior rectangular digital temperature display (factory installed).
- ADA compliant models with 34" (864 mm) work surface height.
- Low profile models with 31 ⅞" (810 mm) work surface height.

PLAN VIEW

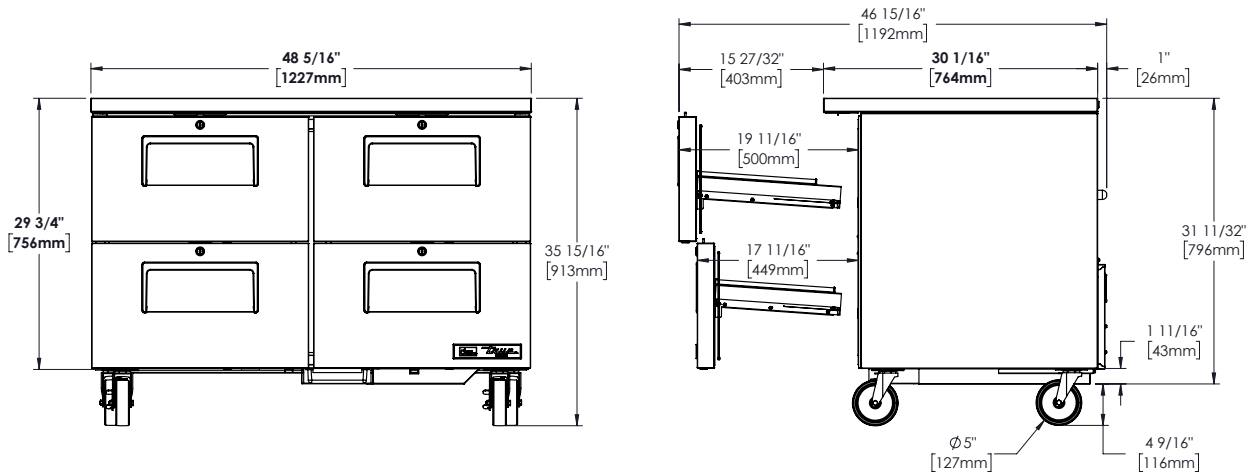

METRIC DIMENSIONS ROUNDED UP TO THE NEAREST WHOLE MILLIMETER

SPECIFICATIONS SUBJECT TO CHANGE WITHOUT NOTICE

KCL	Model	Elevation	Right	Plan	3D	Back
	TUC-48F-D-4-HC					

TRUE MANUFACTURING CO., INC.

2001 East Terra Lane • O'Fallon, Missouri 63366-4434 • (636)240-2400 • Fax (636)272-2408 • Toll Free (800)325-6152 • Intl. Fax# (001)636-272-7546 • www.truefmfg.com