



DUKERS

Quality Commercial Refrigeration



UNDERCOUNTER REFRIGERATOR

MODEL DUC48R

2-Door



PRODUCT FEATURES



The back mount compressor structure is placed in the coolest possible area, provides quick and easy service.



Digital temperature controls with LED display for precise adjustment and automatic defrosting system.



Temperatures in the cabinet range from 33 to 41 degrees Fahrenheit



Higher Resistance to dust, high quality condenser.



R290 Natural Refrigerant, promotes faster cool down and efficient energy consumption



Self-closing doors at 60° with stay open feature.



Stainless steel inside and outside, sealed interior floors and rounder cabinet corners for easy cleaning.



High quality coated stainless adjustable shelves prevent peel and rust.



Lifetime warranty on hinges.



TECHNICAL SPECIFICATIONS

Voltage/Frequency	115V/60Hz
Refrigerant	R290
Type of Defrost	Automatic
Interior Material	Stainless Steel
Exterior Material	Stainless Steel
Temperature Range °F	33 ~ 41°F
Compressor Power (HP)	1/5
Nema Config.	NEMA5-15P



HIGH QUALITY STAINLESS STEEL & ROBUST DESIGN

DETAILS & SPECIFICATIONS

UNDERCOUNTER DUC48R

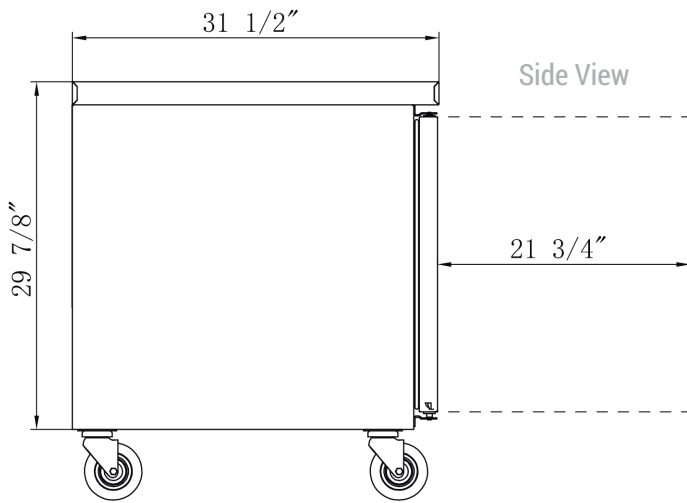
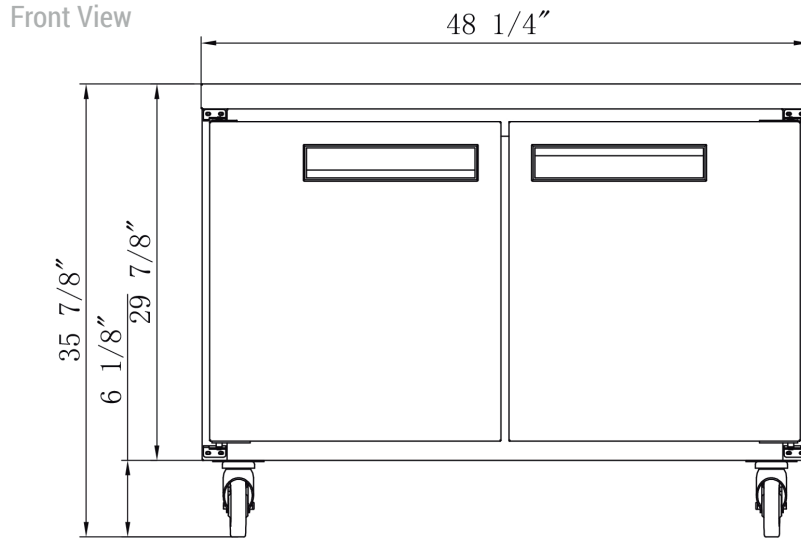

MODEL DUC48R

Rated Voltage	115V
Rated Frequency	60Hz
Total Input Power	280W
Total Current	2.4A
Total Capacity	12.21 cu ft
Climatic Category	4-5
Protection Type	I
Design Pressure High Side	300 PSIG
Design Pressure Low Side	150 PSIG
Insulation Blowing Gas	C-Pentane
Refrigerant	R290/3.17oz

MODEL	EXTERNAL DIMENSION WXDXH (INCHES)	PACKAGING DIMENSION WXDXH (INCHES)	PRODUCT NET WEIGHT	# OF SHELVES	40HQ CONTAINER CERT.
DUC48R	48 1/4 x 31 1/2 x 36	49 5/8 x 33 1/8 x 39 3/8	211 lbs	2	46



115/60/1
NEMA-5-15P