



# DUKERS

Quality Commercial Refrigeration



## UNDERCOUNTER REFRIGERATOR

MODEL DUC29R  
Single Door











### TECHNICAL SPECIFICATIONS

Voltage/Frequency	115V/60Hz
Refrigerant	R290
Type of Defrost	Automatic
Interior Material	Stainless Steel
Exterior Material	Stainless Steel
Temperature Range °F	33 ~ 41°F
Compressor Power (HP)	1/5
Nema Config.	NEMA5-15P



### PRODUCT FEATURES

-  The back mount compressor structure is placed in the coolest possible area, provides quick and easy service.
-  Digital temperature controls with LED display for precise adjustment and automatic defrosting system.
-  Temperatures in the cabinet range from 33 to 41 degrees Fahrenheit
-  Higher Resistance to dust, high quality condenser.
-  R290 Natural Refrigerant, promotes faster cool down and efficient energy consumption
-  Self-closing doors at 60° with stay open feature.
-  Stainless steel inside and outside, sealed interior floors and rounder cabinet corners for easy cleaning.
-  High quality coated stainless adjustable shelves prevent peel and rust.
-  Lifetime warranty on hinges.



### HIGH QUALITY STAINLESS STEEL & ROBUST DESIGN

# DETAILS & SPECIFICATIONS

## UNDERCOUNTER DUC29R

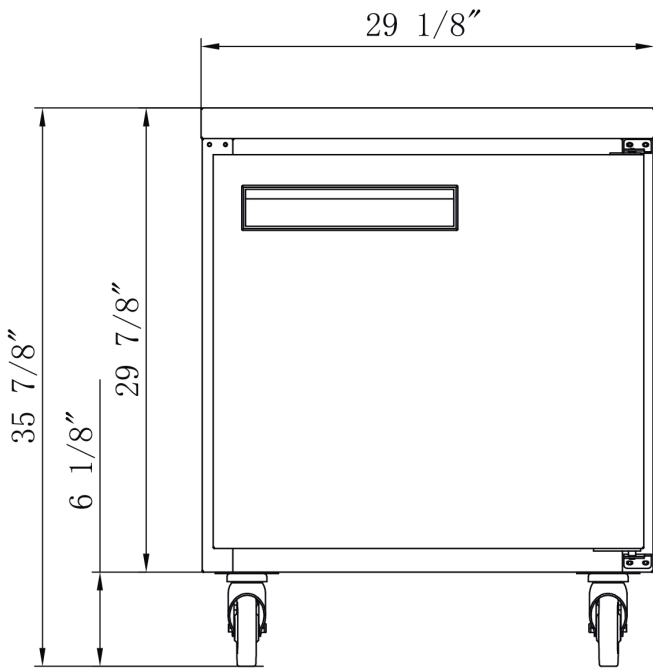

Front View

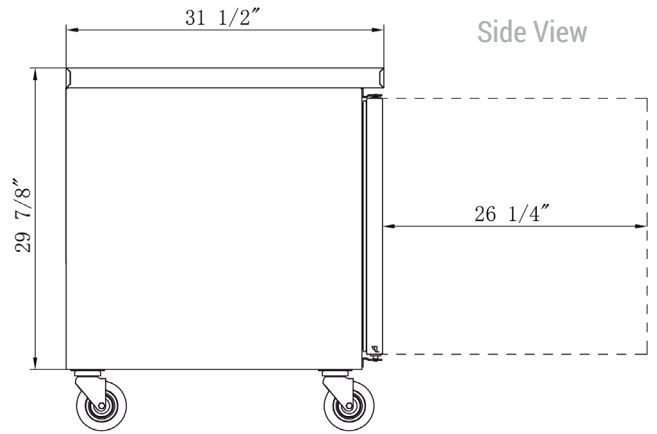

Side View

### MODEL DUC29R

Rated Voltage	115V
Rated Frequency	60Hz
Total Input Power	225W
Total Current	2.0A
Total Capacity	6.99 cu ft
Climatic Category	4-5
Protection Type	I
Design Pressure High Side	300 PSIG
Design Pressure Low Side	150 PSIG
Insulation Blowing Gas	C-Pentane
Refrigerant	R290/2.82 oz

MODEL	EXTERNAL DIMENSION WXDXH (INCHES)	PACKAGING DIMENSION WXDXH (INCHES)	PRODUCT NET WEIGHT	# OF SHELVES	40HQ CONTAINER CERT.
DUC29R	29 1/8 x 31 1/2 x 36	30 1/2 x 33 1/8 x 39 3/8	158 lbs	1	60



AutoQuotes



115/60/1  
NEMA-5-15P