

Item # \_\_\_\_\_

Qty # \_\_\_\_\_

Model # \_\_\_\_\_

Project # \_\_\_\_\_



**DUKERS**  
Quality Commercial Refrigeration

# STOCK POT

DCSPB2



Catch Tray



Ventilation



Legs



Knobs



Cast Iron  
Cooking Surface



## PRODUCT DESCRIPTION

- ✦ Stainless steel sides and front valve cover.
- 🔧 Stainless steel tubing for pilots and pilot tips per burner ring.
- 🔥 Heavy duty cast iron three-ring burner, rated at a total of 160,000 BTU/h.
- 🔧 Each burner is equipped with two continuous pilots.
- 🔧 Heavy duty cast iron and top grates.
- 👉 Two manual controls to operate the inner and outer rings independently.
- 🔧 3/4" NPT rear gas connection and regulator standard.
- 🔧 Stainless steel legs standard.
- 🔧 Full length seamless drip pan for easy cleanup.



**HIGH QUALITY  
STAINLESS STEEL &  
ROBUST DESIGN**



STOCK POT  
MODEL

DCSPB2

### DIMENSION

Width	Depth	Height
18 in	42 1/4 in	18 in

# DETAILS & SPECIFICATIONS

## STOCK POT DCSPB2

Front View

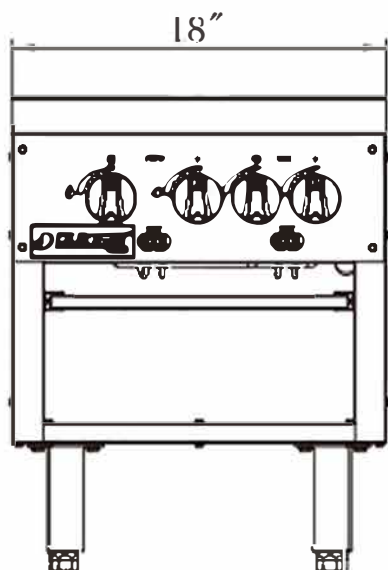

Top View

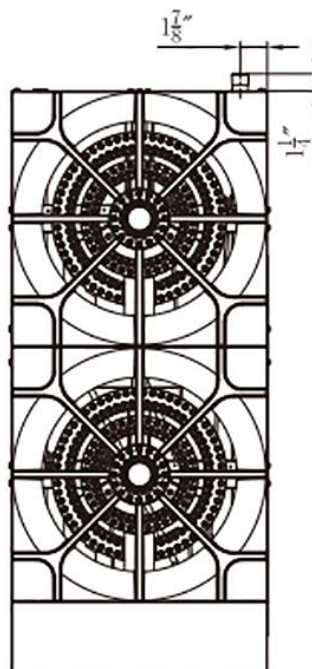

Side View

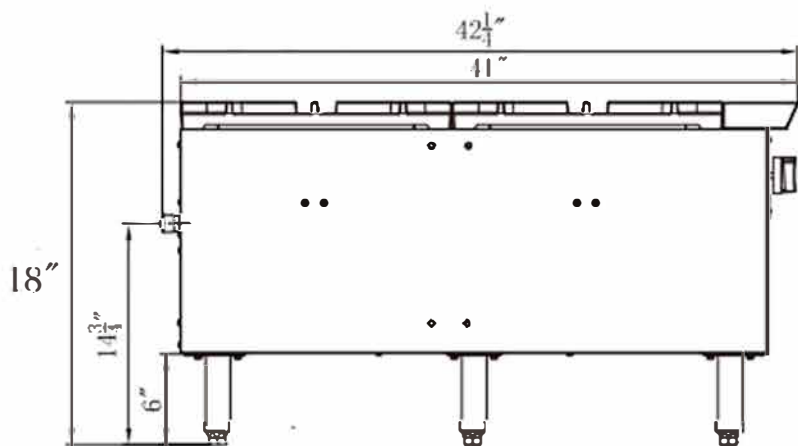

### DCSPB2

GAS SOURCE	NG/Propane
COOKING AREA	18x41 in
BURNER	4 count
SINGLE BURNER	40000 BTU/H
COMBINED	160000 BTU/H
GAS PRESSURE	NG: 5 "WC Propane: 10 "WC
NOZZEL	NG: 32# Propane: 48#

Model	Packaging Dimensions (inches)			Net Weight (lbs)	Ship Weight (lbs)	Container Capacity 40'HQ
	W	D	H			
DCSPB2	21 1/8"	45 1/2"	22 1/2"	224	310	132