

Item # _____
 Qty # _____
 Model # _____
 Project # _____



DUKERS
 Quality Commercial Refrigeration

**STOCK
 POT**
 DCSPB1



Catch Tray



Ventilation



Legs



Knobs



Cast Iron
 Cooking Surface



PRODUCT DESCRIPTION

- Stainless steel sides and front valve cover.
- Stainless steel tubing for pilots and pilot tips per burner ring.
- Heavy duty cast iron three-ring burner, rated at a total of 80,000 BTU/h.
- Each burner is equipped with two continuous pilots.
- Heavy duty cast iron and top grates.
- Two manual controls to operate the inner and outer rings independently.
- 3/4" NPT rear gas connection and regulator standard.
- Stainless steel legs standard.
- Full length seamless drip pan for easy cleanup.



**HIGH QUALITY
 STAINLESS STEEL &
 ROBUST DESIGN**



**STOCK POT
 MODEL**

DCSPB1

DIMENSION

Width	Depth	Height
18 in	24 1/4 in	18 in

DETAILS & SPECIFICATIONS

STOCK POT DCSPB1

Front View

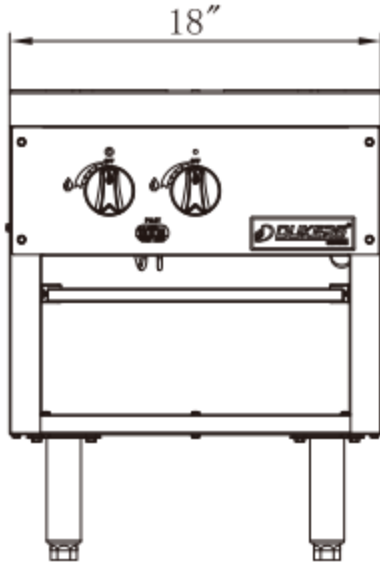

Side View

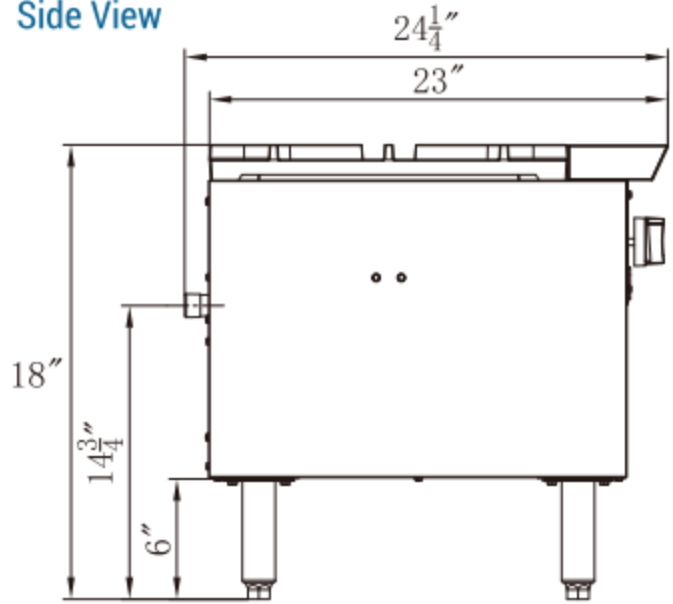

Top View

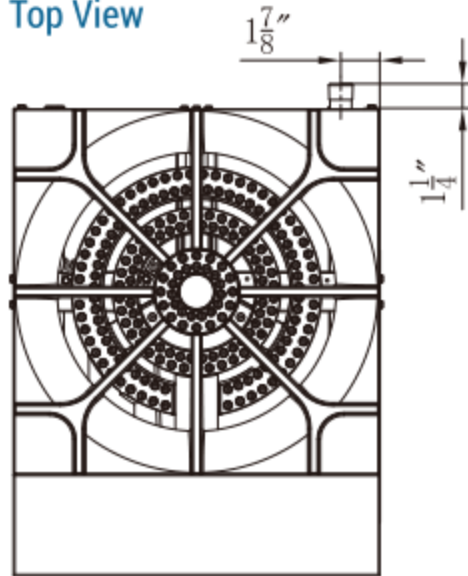

DCSPB1

GAS SOURCE	NG/Propane
COOKING AREA	18x18in
BURNER	2 count
SINGLE BURNER	40000 BTU/H
COMBINED	80000 BTU/H
GAS PRESSURE	NG: 5 "WC Propane: 10 "WC
NOZZEL	NG: 32# Propane: 48#

Model	Packaging Dimensions (inches)			Net Weight (lbs)	Ship Weight (lbs)	Container Capacity 40'HQ
	W	D	H			
DCSPB1	21 1/8"	27 1/2"	22 1/2"	115	157	292