

Item # _____

Qty # _____

Model # _____

Project # _____



DUKERS

Quality Commercial Refrigeration



GAS RANGE

DCR60-10B / 10 Burner Gas Range



Knobs



Cooking Surface



PRODUCT DESCRIPTION

- ✦ Stainless steel exterior including front, back sides, kick plate, back guard and over shelf
- 🍳 Heavy duty 12" X 12" removable, cast iron top grates
- 🌡️ Oven temperature range between 175°F to 500°F
- 🔌 3/4" NPT rear gas connection and regulator standard.
- 🍽️ Two(2) chrome oven rack per oven standard, multiple position oven rack guides
- 🧼 Enamel interior oven for easy cleaning.
- 🛞 6" casters with lock for easy mobility.



HIGH QUALITY STAINLESS STEEL & ROBUST DESIGN

GAS RANGE MODEL	DIMENSION		
	Width	Depth	Height
DCR60-10B	60 in	31 1/2 in	56 in

DETAILS & SPECIFICATIONS

DCR60-10B

Front View

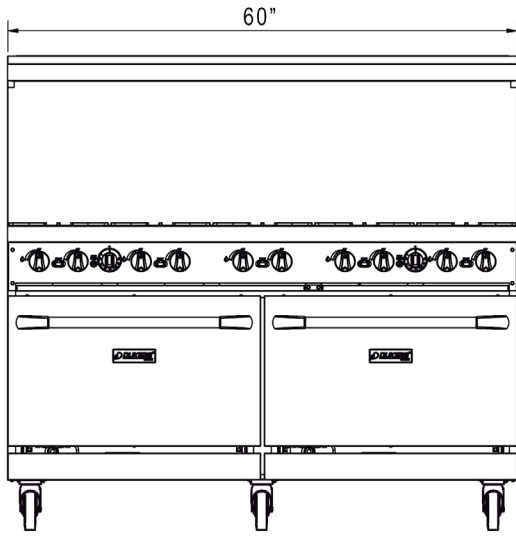

Side View

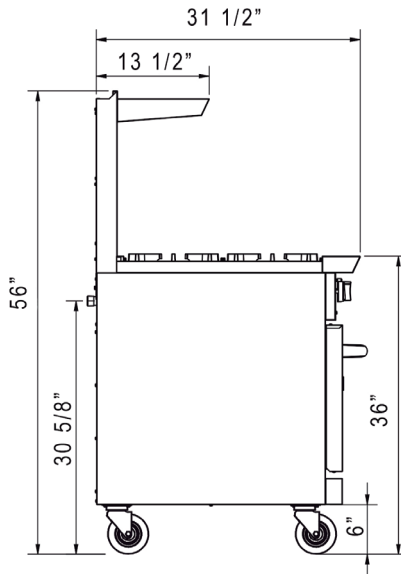

Top View

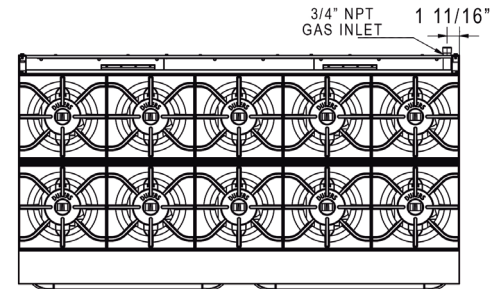



 SANITATION C US
 Conforms to NSF/ANSI7 (ETL)

PROUD MEMBER

 Commercial Food Equipment Service Association

Product Specifications

WORKING AREA 60" x 24"

GAS TYPE LPG/NG

BURNERS
 SINGLE OUTPUT BTU
 NOZZLE #
 TOTAL OUTPUT BTU
 GAS PRESSURE

	LPG		NG	
	HOT PLATE	OVEN	HOT PLATE	OVEN
BURNERS	10	2	10	2
SINGLE OUTPUT BTU	30000 BTU	35000 BTU	33000 BTU	35000 BTU
NOZZLE #	52	49	41	38
TOTAL OUTPUT BTU	370000 BTU		400000 BTU	
GAS PRESSURE	10		5	

Model	Packaging Dimensions (inches)			Net Weight (lbs)	Ship Weight (lbs)	Container Capacity 40'HQ
	W	D	H			
DCR60-10B	62"	36 4/5"	38 1/5"	597.52	716.10	44