



DUKERS
Quality Commercial Refrigeration

Item # _____
Qty # _____
Model # _____
Project # _____



FRYER

THREE TUBE BURNER

DCF3-LPG / DCF3-NG



Fryer Burner



Fryer Baskets

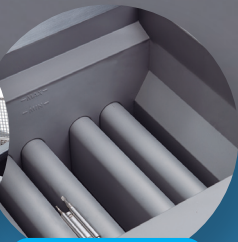

Oil Tank



PRODUCT DESCRIPTION

- Three highly efficient red tube, cast iron burners create a large heat-transfer area for reliable, even heat distribution. Our durable temperature probe senses temperature changes and activates a quick burner response.
- The temperature for the DCF3-LPG/DCF3-NG ranges from 200°F (93°C) to 400°F (204°C). Includes Millivolt safety control system.
- Every inch of the frypot and cold zone can be cleaned and wiped down by hand.
- The large cold zone and forward sloping bottom help collect and remove sediment from the frypot to safeguard oil quality and support routine frypot cleaning.



HIGH QUALITY STAINLESS STEEL & ROBUST DESIGN

* All measures are presented in Inches

FRYER MODEL	DIMENSION		
	Width	Depth	Height
DCF3-NG	15 1/2 in	32 7/8 in	45 in
DCF3-LPG	15 1/2 in	32 7/8 in	45 in

DETAILS & SPECIFICATIONS

FRYER DCF3-LPG / DCF3-NG

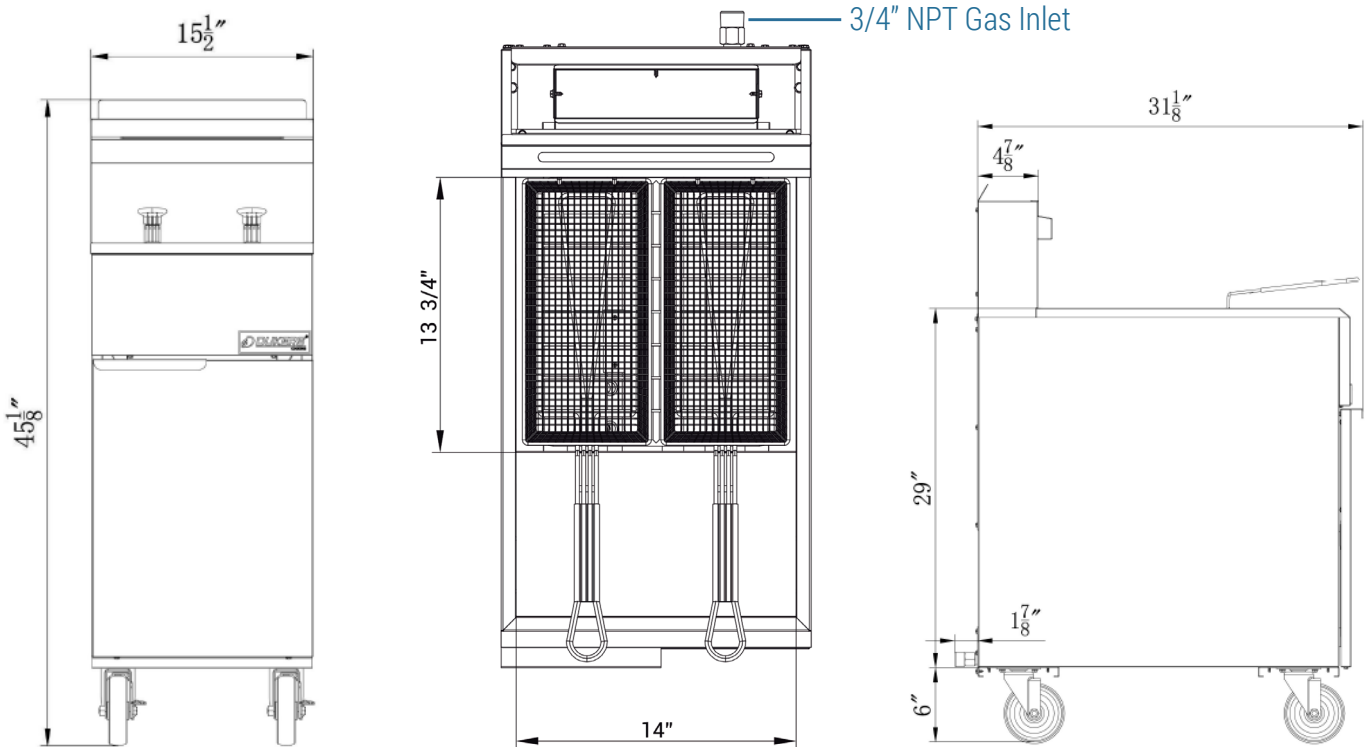

Front View

Top View

Side View

DCF3-LPG

GAS SOURCE	LPG
WORK AREA	14.01x13.98in
BURNER	3 count
SINGLE BURNER	30000 BTU/H
COMBINED	90000 BTU/H
OIL TANK CAPACITY	40 lbs
GAS PRESSURE	10 "WC
NOZZEL	52#
CONTAINER FITMENT	130

DCF3-NG

GAS SOURCE	NG
WORK AREA	14.01x13.98in
BURNER	3 count
SINGLE BURNER	30000 BTU/H
COMBINED	90000 BTU/H
OIL TANK CAPACITY	40 lbs
GAS PRESSURE	4 "WC
NOZZEL	39#
CONTAINER FITMENT	130

Model	Packaging Dimensions (inches)			Net Weight (lbs)	Ship Weight (lbs)
	W	D	H		
DCF3-LPG	17 7/8"	35 3/8"	37 5/8"	165.35	187.39
DCF3-NG	17 7/8"	35 3/8"	37 5/8"	165.35	187.39

